

# PRODUCT MANUAL



## **MODEL:CP-7** Rooder

Please Read This Owner's  
Manual Carefull Before Oper-  
ating This Vehicle

## Chapter 1 Products Introduction

This scooter has 3D design, beautiful appearance, unique style and leisure structure, which let you fall in love at first sight.

### Main characteristics are as follows:

1. Lithium battery: Products approved by UL and CE certification and registrations of the safety inspection, so it's safe and reliable; The vehicle has lithium batteries, which have a long life and don't need often change; Lithium battery is 3 times lighter than lead-acid battery;

Products have high voltage and power, climbing speed is fast; Recognized as a green energy, no any pollution in the whole process of the production and use.

2. Battery: Hidden in the center of the pedal beneath, force equilibrium, small, light, safe.

3. Motor: The best magnetic steel material is qualitative, the high quality silicon steel sheet, bold coil, precision bearings, gross motor shaft, powerful and durable.

4. Tire: Using ultra wide beach car straight grain vacuum tires, generous compaction, better stability and more grip, braking distance is shorter, comfortable and soft.

5. Frame: From 3D virtual design and assembly, to the advanced technology of automatic pipe bending, let you sit or stand.

6. Disc brake: The cabinet and delicate hydraulic disc brake, the pump body aluminum alloy forging technology, advanced CNC processing technology, flexible, and the braking action freely.

7. The steering wheel: Leisure streamlined human body engineering design, tough and firm, allowing you to easily be manipulated..

8. Handles: using soft rubber let hand feels comfortable.

9. Seat cushion: high elastic foam, senior anti-slip leather, elaborate design and perfect appearance, proper high, let long ride more comfortable.

10. Smart charger: according to the automatic portable design, charging is easy, wherever there is 220V ac power supply, rechargeable use.

11. Controller: special set-up, soft start, no sense of frustration, driving safer.

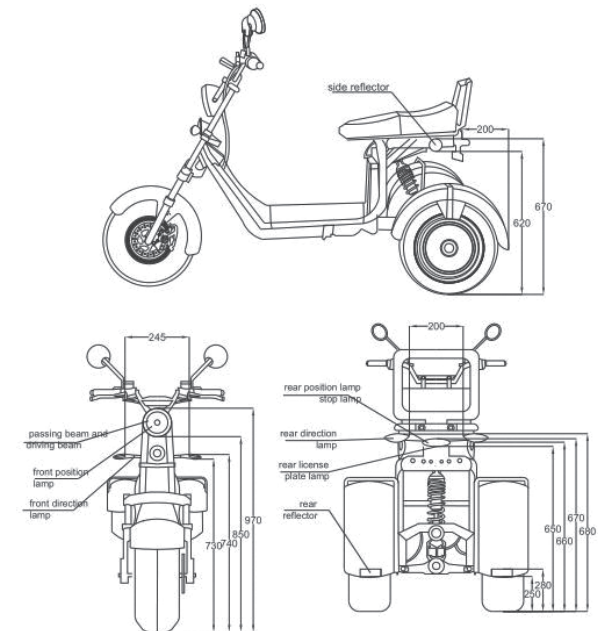

## Chapter 3 Main Technical Parameters

### I. Main technical parameters of the scooter

1. Product Size: 1870 \* 850 \* 1145mm

2. Wheelbase: 1540 mm
3. High: 1045mm
4. Weight: 70kgs
5. Tire specifications: Axle 1: 225/40-10 M/C Axle 2: 225/40-10
6. Maximum load: 200 kgs
7. Design top speed:  $\leq 45$  km/h
8. Range: 40 ~ 60 km
9. Maximum torque: 95 N/M
10. Maximum climbing:  $\leq 18^\circ$
11. Braking performance (20 km/h):  
Dry:  $\leq 1$  m; Wet:  $\leq 3$  m

## II. Main technical parameters of battery

1. Battery type: 18650 lithium-ion batteries
2. Capacity: 12AH~20AH
3. Nominal voltage: 60V

## III. Main technical parameters of motor

1. Motor models: brushless dc motor hub
2. Rated power: 2000W\*2000w

## IV. Main technical parameters of controller

1. Current limiting protection value:  $45 \pm 1$  A
2. Under-voltage protection value:  $47 \pm 0.5$  V

## V. Charger main parameters:

1. The input voltage (ac): 100-240VAC  
50/60HZ
2. The output voltage (dc): 67.2 ~2.0A
3. Charging time (the remaining power the case may be): 8 ~ 10 h

**Note: the above parameters can be changed by the manufacturer without prior notice, check the company technical Parameters of model library!**

# Chapter 4 Methods of use and moments which needed attention

## I. Precautions for safe driving

1. Please check the traffic rules and pay attention for safety and speed control, please ride with safe speed (pay attention to the local accepted speed).
2. Before riding, get familiar with the contents of this manual first, and then find a empty field for practice, be sure with controlling of the vehicle riding essentials, get familiar with the structure and properties of the local regulations, this is the foundation of safe riding.
3. Do not lend the vehicle to not familiar with it riders. Single hand riding or drunk riding is very dangerous.
4. Riding in rainy and snowy days you have to double pay attention to safety, rain and snow will bring danger for the riding and controlling the vehicle!  
Therefore, we should avoid high speed, also turn carefully, especially should remember brake in advance is snowy day.
5. The correct using of helmet: put a helmet right on the head, and tie-down straps.
6. Correct clothes: don't wear tights, the whole body should move freely, don't open your clothes; wear low heels as much as possible.  
Note: in order to facilitate maintenance, repair and service, every vehicle has a frame. number and motor number, to help dealer provide you better service let him know this information
7. The vehicle can't overweight: default of maximum load of 200 kg. The riding with heavy load on the bike is different; it will be harder to control the vehicle.

## **II. The correct method of use**

### **1. The riding method**

- ① Keep the natural posture.
- ② Riding posture: please both hands on the steering bar and both feet on the vehicle
- ③ Riding posture: accelerate slowly, avoid catching up rider's instability.
- ④ Ride slow on paved road surface.
- ⑤ Rain and snow weather, road surface wet easy to slide, focus on riding slowly; Avoid deep water where the battery box can go in the water, avoid the vehicle electric parts damage caused by short circuit. Braking performance will decline at the same time, easy to cause an accident.

### **2. The way of parking**

- ① Pay attention while parking especially when other vehicles and pedestrians around, slowly go to the dock flat road on the right side, avoid parked on the ramp.
- ② After the vehicle stopped, lock a right-handle and pull off the power supply, then use locks to lock.

### **3. The power indicator method of use**

Turning on the power supply voltage indicator, full electric LOW \ HALF \ HIGH - 3 Led-lights, HIGH lights that electricity used up 75% of the rated capacity, HALF lights charge 25% of the rated capacity, LOW lights flashing indicates that power is less than 10%; So when you find LOW lights flashing charge immediately.

### **4. The use of the power lock key**

Turn the ignition key right to start the motor. Use the keys to turn on and shut off the power, Turn left to shut off the power locks. Turn off the power supply after parking, power locks shall be counterclockwise, then pull out the key.

### **5. Acceleration handle (speed)**

Rotate in the direction of the rider to accelerate, relax accelerator for reduction acceleration.

## **6. The use of the disc brake method and matters needing attention**

### **(1) The use of the disc brake**

- ① The brake clearance adjustment: turn the adjusting nut by 2 mm by wrench (between the brake lever and handlebar tube), adjust the gap of between disk and pads, until you feel comfortable position.
- ② The brake pads should be changed every six months, more than 1 mm clearance or brake linings on the handle - adjusting nut has to adjust; Replace the brake pads, with a clean environment with a screwdriver to press the one piece of brake pads into, with empty space to take out another piece, after replacement of the new brake pads, need to put the brake on the brake lever adjusting screw back into the right position (when you feel comfortable position).
- ③ Period: It takes time for pads to adjust themselves. After adjusting braking force will increase obviously.
- ④ Oil change: the disc brake using mineral oil, if brake handle feels weak, oil need to be replaced (usually 2 ~ 3 years), straw with a syringe pump oil change.

### **(2) The moments needed attention**

- ① Please do not in the vicinity of a disc, brake discs and brake pads and calipers used lubricating oil, do not touch directly with the hand disc brake disc and brake pad surface, otherwise, can significantly reduce the braking performance.
- ② New brake shouldn't be poured by water, in order to avoid a small amount of lubricating oil in the assembly clearance pollution to the brake pads.
- ③ Hydraulic disc brake system has strong power, so you need to practice in a safe place, avoid energetically knead dead brake, cause the wheel lock will be out of control and injured.

## **7. Using of the charger**

### **(1) Method of use**

- ① While charging, first insert the battery box, and then plugged into mains AC220V plug. After charging, on the other hand, the first grid AC220V plug, pull out the battery box plug again.

② Normal charging, charging indicator light shows red, full charge - the charge indicator shows green.

③ If the temperature doesn't fit for charging, a red light will be flashing, that means the charger is in a state of temperature protection, please put the charger moved to a cool and ventilated place to use.

④ When used without access to the battery, charger output is less than 42 v pulse voltage, when testing in the output port between plus or minus 1 kΩ resistance load, you can test the actual charger charging voltage.

(2) The moments needed attention

① The charger can only be used indoor.

② It is strictly prohibited in the confined space or under the scorching sun and high temperature environment, cannot put the charger in barrels or in the box.

③ Is prohibited connect the charger light on the ac power source for a long time without charge.

④ In the process of charging, such as the abnormal light, odor or overheating charger shell, should immediately stop charging and send the charger for repair or replacement.

⑤ Shall not be open and fix charger inside

⑥ To should not overcharge the battery.

⑦ Don't use in a combustible gas environment, which may cause fire or explosion.

⑧ Don't put the charger near water or wet place, is likely to fire or get an electric shock.

## **8. Use method and matters needing attention of the battery**

(1) Charging

① Be sure to use the company specially equipped charger to charge; Informal or unqualified charger, can lead to shorten the battery life or battery failure!

② Completely discharge the battery can't be down more than 95%

⑤ Storage more than a month, the battery charge capacity will reduce about 5%

⑥ Please charge in time, to ensure the mileage.

⑦ The charger may work incorrect, as long as the temperature is not more than 60, that is normal.

⑧ While charging, please put the charger and the whole vehicle stable, dry, no inflammable, explosive, and out of the reach of children.

⑩ Attending charge shall not be short circuit.

(2) The discharge (use)

① Can only be used in the electric vehicle batteries, shall not be used for other purposes, otherwise no warranty.

② In case of short circuit, battery management system will have automatic protection, and the power cord of the concatenated insurance will fuse, double protect your battery, short circuit and replace when terminates after about 2 minutes, the battery can work normally.

③ Controller of the electric car, motor, speakers, lighting equipment damage or configuration is not reasonable, all can lead to large current discharge batteries, the battery has protective stop output, but will be back in 10 seconds, ride for you will not have any impact.

④ Battery operating temperature range: -10 °C~55°C, like other cells, with lower temperature, the use of battery energy decreases, belongs to the normal phenomenon.

⑤ Not discharge completely for avoiding short circuit.

(3) Storage

① Such as storage for a long time (more than a month), suggested charging to 60%~80% of the battery; Store every three months during the need to supply electricity, battery also need to supplement battery before use.

② The battery should be kept in a cool, dry environment.

③ Storage should be avoided in the process of conducting objects across the electrodes will be directly connected.

④ Near the fire source shall be forbidden to use the battery.

⑤ Disassemble the battery is prohibited.

⑥ Can't be use modification on batteries.

(4) Note

① If battery deformation or heat is found, should stop to use, and contact the company or the maintenance department for help.

② Such case as a fire, do not use water directly to the battery fire extinguishing, the proposal USE sand covering, foam fire extinguisher and thick cloth soaked with water and the fire extinguishing methods of dealing with organic solvent.

③ Damage because not correct storage or charging will be not covered by warranty.

④ Cannot be arbitrarily discarded batteries.

### III Inspection, cleaning and maintenance

#### 1. On a regular basis or daily check item

① Note on the vehicle in a safe location.

② Abnormal position the day before, to see whether affect operation.

③ Brake braking effect: the brake handle modest fashion is downy, clearance, whether can normal braking.

④ Crack, damage, abnormal tire, as well as metal, stone, glass and other sharp objects embedded; The depth of the grooved tires, tires has to be changed to new tires when you wear off two-thirds; According to the situation of tire contact with the ground part of the sag, check the tire pressure, normal pressure values before and after the tire is 1.5 kg/cm<sup>2</sup>.

⑤ Power voltage indicates whether or not the full check article 3 (in chapter 4, paragraph 2).

⑥ Steering system check: up, down, forward, backward, left, right handlebar and front fork, elastic moderate, flexible steering, if there is a touch attack clattering sound, loose steering system, a sound and other issues, please contact with dealers, to provide you with the most perfect after-sale service.

⑦ Front and rear axle is loose.

### IV Common faults and elimination method

No	Performance	Reason	Solution
1	Speed regulation failure or maximum speed reduced	①The battery voltage is too low; ②Speed control to turn the failure; ③Transfer speed in the spring stuck or failure;	①Full of battery; ②Looking for distributors to replace;
2	The motor power does not work	①The battery's connection is loose; ②Speed control to turn the failure; ③The motor output line is loose or damage;	①Reconnection; ②Looking for distributors to replace; ③Maintenance;
3	Lock of mileage range	①Tire pressure is no sure; ②Under charge or charger malfunction; ③The battery aging or damaged; ④Complex road conditions;	①Make sure of tire pressure; ②Full of charge or replace the charger; ③Replace the battery; ④Cycling conditions change is back to normal;
4	The charger is not working	①Socket and plug connection is loose; ②Battery compartment within the fuse blew out; ③Cable fall off;	①Make sure of socket and plug; ②Replace the fuse; ③Welding the cable;
5	Other	Cannot determine the fault	Looking for distributors or professional maintenance depot

## Chapter 5 Electrical Principle

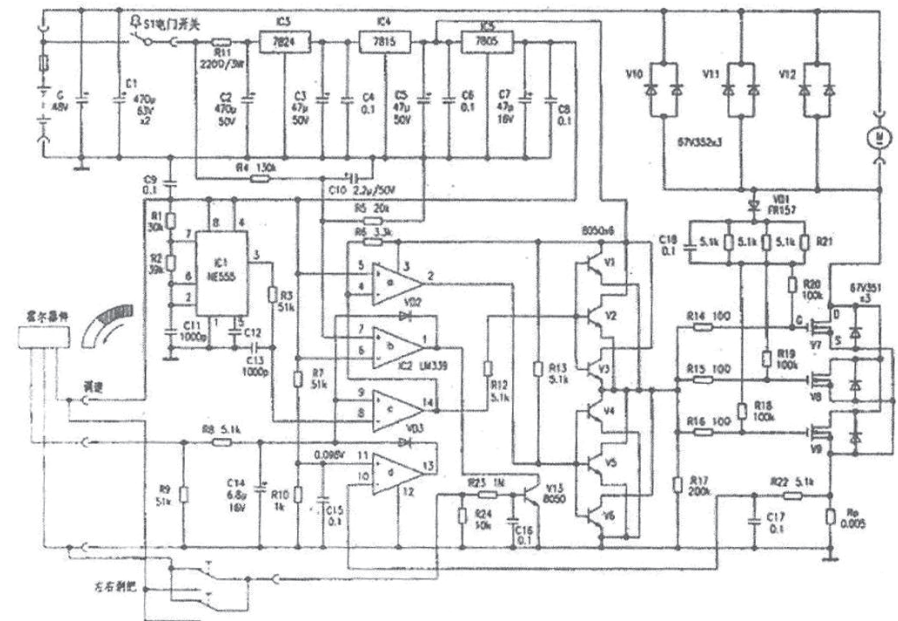

## Chapter 6 Quality assurance and after-sales service

According to the consumers' rights and interests of the People's Republic of China protects a law "the legal provision, with reference to the relevant document issued by state bureau of technical supervision in order to effectively protect the legitimate rights and interests of consumers, improve product quality civil liability system, also facilitate travel 3 packets (repair, replacement or return) obligations and responsibilities, on the strength of the warranty card to sell car units designated by the maintenance department enjoys a" 3 Guarantee "service, specific provisions are as follows:

### 1. "3 Guarantee" in the scope of the repair, replacement or return

- ① please check on the vehicle when it is entitled to request sales staff to provide effective bill and warranty card, as well as the maintenance unit's address and telephone number.
- ② after a car you should read the instruction for use to master the correct method of use and daily maintenance and matters needing attention
- ③ user operation when used properly according to product manuals within 7 days from the date of products sold in performance failure. Costumer can choose a replacement or repair.
- ④ in 3 guarantee of period of validity, Cant repair many times to repair that cannot be used properly, the strength of the repair units to provide repair records and certificate, identified through after-sales service of the company headquarters, can exchange models of products for consumers, changing the same products, in accordance with the provisions, charging depreciation cost (2.7%), the vehicle every day, for the battery will not be used by the exchange.

### 2.Appraisal standard warranty

No	Part	Replace the standard	Can't replace the standard	Replace time
1	Hand cube	breakage	Improper use or man-made factors;	1 year
2	Fork	breakage; sealing-off	Improper use or man-made factors;	2 years
3	Framework	Breakage; sealing-off	①Improper use or man-made factors; ②Welding nut off; ③The changing structure of the framework;	2 years
4	Wheel tyre	Entire breakage; dew wire	①Improper use or man-made factors; ②Over wear;	3 month
5	Motor	Bearing broken; Casing damage	①Improper use or man-made factors; ②Corroded broken or polluted; ③Missing parts or don't match;	2 years
6	Controller	failure	Improper use or man-made damage;	1 year

No	Part	Replace the standard	Can't replace the standard	Replace time
7	Charger	breakage	Improper use or man-made factors;	1 year
8	Lithium battery	Within 15 months since the factory capacity attenuation is less than 80%, in the new battery;16 to 24 months capacity attenuation is less than 70%, in after-sales battery	①by charging and discharging test, which can meet the capacity; ②human factors or improper use of casing damage, incorrect use charger, tear open outfit, secretly use (more than 60℃) in high temperature and long time large current discharge, artificial flooding short circuit, etc	2 years
9	Disc brake	Upper and lower oil pump oil leakage, breakage, brake handle manufacturing defect and fracture, such as oil tubing defects	①Improper use or man-made factors; ②Users to change; ③Serious defect attachment;	1 year
10	Flat fork	Breakage	①Improper use or man-made factors; ②Users to change; ③Serious defect attachment;	1 year
11	The main frame	Breakage	①Improper use or man-made factors; ②Corroded broken or polluted; ③Missing parts or don't match;	1 year
12	The main cable	caused by short circuit, fracture, corrosion in natural	①To change the cable; ②Cable surface wear;	3 month

### 3. Don't belong to the scope and content of "3 guarantees"

- ① Users are not used as stipulated in the operating instructions, maintenance or adjustment caused by the fault;
- ② Users are modified, folded repair the damage and its own decomposition, the failure of the original state, not for technical appraisal and analysis of fault;
- ③ Use the parts and modifications not from official dealer.
- ④ Users, maintain undeserved or failure caused by accidents;

