

EEC

EEC



PRODUCT MANUAL

Rooder

MODEL:CP-2

Please Read This Owner's Manual Carefully Before Operating
This Vehicle

Chapter 1 Products Introduction

This scooter is to use 3D design, beautiful appearance, unique style and leisure structure, which let you fall in love at first sight.

Main characteristics are as follows:

1.Lithium battery:Products by UL and CE certification and registrations of the safety inspection, safe and reliable;Service life is 3 times of lead-acid batteries, the basic do not need to change - long life;Weight is the 1/3 of lead-acid battery, light weight;

Products with high voltage and powerful, climbing speed fast, high energy; Recognized as a green energy, no any pollution in the whole process of the production and use.

2.Battery: Hidden in the center of the pedal beneath the surface, force equilibrium, small,light, safe.

3.Motor:The best magnetic steel material is qualitative, the high quality silicon steel sheet, bold coil, precision bearings, gross motor shaft, powerful and durable.

4.Tire:Using ultra wide beach car straight grain vacuum tires, generous compaction, better stability and more grip,braking distance is shorter, no worry about flat tire, ride safe, comfortable and soft.

5.Frame:From 3D virtual design and assembly, to the advanced technology of automatic pipe bending, robot automatic welding with one super pedals, grind arenaceous non-slip, let you sit or stand, ride safe.

6.Disc brake:The cabinet and delicate hydraulic disc brake, the pump body aluminum alloy forging technology, advanced CNC processing technology, flexible, and the braking action freely.

7.Direction:Leisure streamlined human body engineering design, tough and firm, allowing you to easily manipulated.

8.Hand tube: using soft rubber mold injection molding, let your hand feels comfortable.

9.Seat cushion:adopt new plastic material plate, high elastic foam, senior anti-slip leather, elaborate design and perfect appearance, proper high, let your long ride more comfortable.

10.Smart charger: according to the automatic portable design, charging without care, wherever there is 220V ac power supply, rechargeable use.

11.Controller: specially set-up, soft start, no sense of frustration, driving safer.



Chapter 3 Main Technical Parameters

I .Main technical parameters of the scooter

- | | |
|---------------------------------------|--------------------------------------|
| 1.Product Size: 1840 * 810* 1200mm | 8.Range: 40 ~ 60 km |
| 2.Wheelbase: 1350mm | 9.Maximum torque: 95 N/M |
| 3.High: 1200mm | 10.Maximum climbing: $\leq 18^\circ$ |
| 4.Weight: 70kgs | 11.Braking performance |
| 5.Tire specifications: 225/40-10 inch | (20 km/h) : |
| 6.Maximum load: 200 kgs | Dry: ≤ 1 m ;Wet: ≤ 3 m |
| 7.Design top speed: ≤ 45 km/h | |

II .Main technical parameters of battery

- 1.Battery type: 18650lithium-ion batteries
- 2.Capacity: 12AH~20AH
- 3.Nominal voltage: 60V

III.Main technical parameters of motor

- 1.Motor models: brushless dc motor hub
- 2.Rated power: 1500W

IV.Main technical parameters of controller

- 1.Current limiting protection value: $25 \pm 1A$
- 2.Under-voltage protection value: $52 \pm 0.5V$

V.Charger main parameters:

- 1.The input voltage (ac):100-240VAC 50/60HZ
- 2.The output voltage (dc) : 67.2 ~2.0A
- 3.Charging time (the remaining power the case may be) : 8 ~ 10 h

Note: the above parameters change, the company without prior notice, see company technical Parameters of model library!

Chapter 4 use method and matters needing attention

I .Precautions for safe driving

- 1.Please observe the traffic rules, safety, speed control, please within safe speed (pay attention to the local safe speed within 20 km/h).
- 2.Before driving, familiar with the contents of this manual first, and then find a empty field practice, be sure to complete control of the vehicle driving essentials, familiar with the structure and properties of the local, this is the foundation of safe driving.
- 3.Do not lend or not familiar with and not driving personnel.Single hand or driving after separation, drunk driving is very dangerous.
- 4.Driving rain and snow days to double pay attention to safety, rain and snow day by the damp ground will bring danger!
Therefore, we should avoid high speed, turn to be careful, especially should remember snow day in advance brake in case of accident.
- 5.The correct use of helmet: put a helmet right on his head, and tie-down straps.
- 6.Correct dress: don't wear tights, the whole body to move freely, cuff don't open your clothes, wear low heels as much as possible.
Note: in order to facilitate maintenance, repair and service, our company produces the every car has a frame. size and motor number, to help sales units to provide you with better service.Inscribed on the base plate of the car chassis number, machine number of engraving on the motor shell cover.
- 7.Cargo can't overweight: default of maximum load of 200 kg.And not slide, the manipulation of the hand feeling is different, too much cargo, hand easy to vibrate out of danger, the vehicle stability load for 1 person, pedal before cargo or manned risk is very big.

II. The correct method of use

1 The driving method

- ① Keep the natural posture, can drive.
- ② Driving posture: please keep this mat in the middle of the, often in case of the front wheel load loss, hand tremor and dangerous.
- ③ Driving posture: turning slowly turn the during acceleration, avoid catching up lead to dangerous drivers gravity instability.
- ④ On the road paved road surface damage or debris should slow down.
- ⑤ Rain and snow weather, road surface wet easy to slide, focus on driving slowly; When the road surface water than pedal the battery box below, please don't ride, avoid the vehicle electric parts damage caused by short circuit. Braking performance will decline at the same time, easy to cause an accident.

2 The way of parking

- ① Attention when parking vehicles and pedestrians around, slowly to the dock flat road on the right side, avoid parked on the ramp.
- ② After the car stopped, lock a right-handed and pull off the power supply, then use locks to lock.

3 The power indicator method of use

Turning on the power supply voltage indicator, full electric LOW \ HALF \ HIGH 3 Led-lights, HIGH lights that electricity used up 75% of the rated capacity, HALF lights charge 25% of the rated capacity, LOW lights flashing indicates that power is less than 10%; So when you find LOW lights flashing charging immediately.

4 The use of the power lock

Power lock key clockwise rotation through a gear, can start the motor., not the keys and shut off the power, more can't counterclockwise shut off the power locks, to cut off the power supply motor stalling. Turn off the power supply after parking, power locks shall be counterclockwise, pull out the key.

5 Hand tube(speed)

Rotate in the direction of the driver is accelerated, relax rotary reduction, power of motor stops after a reset.

6 The use of the disc brake method and matters needing attention

(1) The use of the disc brake

- ① The brake clearance adjustment: turn the adjusting nut by 2 mm Allen wrench (between the brake lever and handlebar tube), adjust the gap of between disk and pads, until you feel comfortable position is advisable.
- ② The brake pads wear every six months, more than 1 mm or brake linings on the handle of the location of the adjusting nut has to adjust, you need to change the time; Replace the brake pads, with a clean bottle with a screwdriver to press the one piece of brake pads into, with empty space to take out another piece, after replacement of the new brake pads, need to put the brake on the brake lever adjusting screw back into the right position (you feel comfortable position).
- ③ Period: It takes time, on the surface of the disc brake break-in to completely after running-in, braking force will increase obviously. New brake used in the first week period, the period not to crush the brake, it would have been on ontology and pads Irreversible damage. The right operation method is light with normal cycling brakes, brake pads and brake disc friction are kept moderate.
- ④ Oil change: the disc brake using mineral oil, brake handle feel weak need to be replaced (usually 2 ~ 3 years), straw with a syringe pump oil change.

(2) The matters needing attention

- ① Please do not in the vicinity of a disc brake discs and brake pads and calipers used lubricating oil, do not touch directly with the hand disc brake disc and brake pad surface, otherwise, can significantly reduce the braking performance.
- ② New brake is best not to pour water, in order to avoid a small amount of lubricating oil in the assembly clearance pollution to the brake pads.
- ③ Hydraulic disc brake system has strong power, so you need in a safe place to practice, so as to adapt to its difference with common brake, avoid energetically knead dead brake, cause the wheel lock out of control and injured.

7 The use of the charger

(1) Method of use

- ① When charging, first insert the battery box, and then plugged into mains AC220V plug, charging end, on the other hand, the first grid AC220V plug, pull out the battery box plug again.
- ② Normal charging, charging indicator light shows red, full of, the charge indicator shows green.
- ③ If the temperature of the charge temperature, a red light flashing, the charger is in a state of temperature protection, please put the charger moved to a cool and ventilated place to use, when the internal temperature of the charger to charging 60°back to normal.
- ④ When used without access to the battery, charger output is less than 42 v pulse voltage, when testing in the output port between plus or minus 1 kΩ resistance load, you can test the actual charger charging voltage.

(2) The matters needing attention

- ① The charger can only be used indoor.
- ② It is strictly prohibited in the confined space or under the scorching sun and high temperature environment, can not put the charger in barrels or end charging in the box.
- ③ Is prohibited without charge, connect the charger light on the ac power source for a long time.
- ④ In the process of charging, such as the abnormal light, odor or overheating charger shell, should immediately stop charging, and the charger for repair or replacement.
- ⑤ Shall not be removed or replaced charger inside the device.
- ⑥ To should not recharge the battery.
- ⑦ Don't use in a combustible gas environment, which may cause fire or explosion.
- ⑧ Don't put the charger near water or wet, is likely to fire or get an electric shock.
- ⑨ Ruby by reason of collision damage to the charger to reveal the internal components, please don't touch, is likely to get an electric shock injuries.

(1) Charging

- ① Be sure to use the company specially equipped with the charger to charge; Informal or unqualified charger, can lead to shorten the battery life or battery failure!
- ② Completely discharge the battery stops (electric) can be down more than 95% of the electricity in 5 hours, 8 hours 100% into electricity.
- ③ Charging, banned direct contact with metal is negative at both ends.
- ④ Load products, electricity about 80% of new car should be added before use electric 3 ~ 10 hours.
- ⑤ On hold for more than a month, the battery charge capacity will reduce about 5%, it is recommended to use before charging.
- ⑥ Please charge in time, to ensure the mileage.
- ⑦ All landowners in the process of charging, the charger may be fever, as long as the temperature is not more than 60 °C, that is normal.
- ⑧ Today when charging, please put the charger and the whole car to stable, dry, no inflammable, explosive, and out of the reach of children.
- ⑨ Ruby completely discharge the battery within 24 hours after have to recharge the battery, and charging time at least 3 hours.
- ⑩ Attending charge shall not be short circuit.

(2) The discharge (use)

- ① Can only be used in the electric vehicle batteries, shall not be used for other purposes, otherwise no warranty.
- ② In case of short circuit, battery management system will be automatic protection, and the power cord of the concatenated insurance will fuse, double protect your battery, short circuit and replace when terminates after about 2 minutes, the battery can work normally.
- ③ Controller of the electric car, motor, speakers, lighting equipment damage or configuration is not reasonable, all can lead to large current discharge batteries, the battery is the protective stop output, but will be back in 10 seconds, ride for you will not have any impact.
- ④ Battery operating temperature range: -10 °C~55°C, like other cells, with lower temperature, the use of battery energy decreases, belongs to the normal phenomenon.
- ⑤ Not to discharge mouth short circuit.

(3) Storage

- ① Such as storage for a long time (more than a month), suggested charging to 60%~80% of the battery;Store every three months during the need to supply electricity, battery also need to supplement battery before use.
- ② The battery should be kept in a cool, dry environment.
- ③ Storage should be avoided in the process of conducting objects across the electrodes will be directly connected.
- ④ Near the fire source shall be forbidden to use the battery.
- ⑤ Disassemble the battery is prohibited.
- ⑥ Ban modification on batteries.

(4) Note

- ① Battery deformation or heat is found, should stop to use, and to the company or the maintenance department for help.
- ② Such as a fire, do not use water directly to the battery fire extinguishing, the proposal USES sand covering, foam fire extinguisher and thick cloth soaked with water and the fire extinguishing methods of dealing with organic solvent.
- ③ Because there is no timely to completely discharge the battery charging battery failure caused by not warranty.
- ④ Cannot be arbitrarily discarded batteries.

III. Inspection, cleaning and maintenance

1 On a regular basis or daily check item

- ① Note on the vehicle in a safe location.
- ② Abnormal position the day before, to see whether affect operation.
- ③ Brake braking effect: the brake handle modest fashion is downy, clearance, whether can normal braking.

- ④ Crack, damage, abnormal tyre wear, as well as metal, stone, glass and other sharp objects embedded;The depth of the grooved tyres, tires on the convex block has to be new tires when you wear off two-thirds;According to the situation of tire contact with the ground part of the sag, check the tire pressure, normal pressure values before and after the tire is 1.5 kg/cm².
- ⑤ Power voltage indicates whether or not the full check article 3 (in chapter 4, paragraph 2).
- ⑥ Steering system check: up, down, forward, backward, left, right handlebar and front fork, elastic moderate, flexible steering, if there is a touch attack clattering sound, loose steering system, a sound and other issues, please contact with dealers, to provide you with the most perfect after-sale service.
- ⑦ Front and rear axle is loose.

IV. Common faults and elimination method

No	Performance	Reason	Solution
1	Speed regulation failure or maximum speed reduced	①The battery voltage is too low; ②Speed control to turn the failure; ③Transfer speed in the spring stuck or failure;	①Full of battery; ②Looking for distributors to replace;
2	The motor power does not work	①The battery's connection is loose; ②Speed control to turn the failure; ③The motor output line is loose or damage;	①Reconnection; ②Looking for distributors to replace; ③Maintenance;
3	Lock of mileage range	①Tire pressure is no sure; ②Under charge or charger malfunction; ③The battery aging or damaged; ④Complex road conditions;	①Make sure of tire pressure; ②Full of charge or replace the charger; ③Replace the battery; ④Cycling conditions change is back to normal;
4	The charger is not working	①Socket and plug connection is loose; ②Battery compartment within the fuse blew out; ③Cable fall off;	①Make sure of socket and plug; ②Replace the fuse; ③Welding the cable;
5	Other	Cannot determine the fault	Looking for distributors or professional maintenance depot

Chapter 5 Electrical Principle

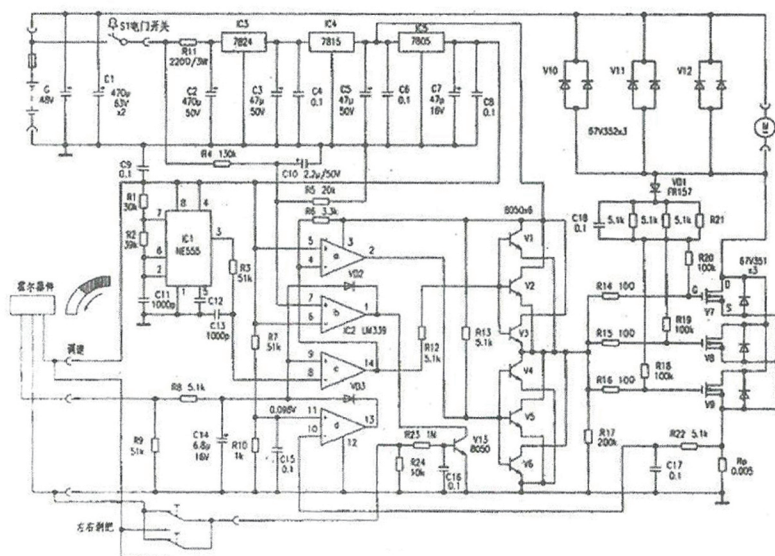

Chapter 6 Quality assurance and after-sales service

According to the consumers' rights and interests of the People's Republic of China protects a law "the legal provision, with reference to the relevant document issued by state bureau of technical supervision in order to effectively protect the legitimate rights and interests of consumers, improve product quality civil liability system, also facilitate travel 3 packets (repair, replacement or return) obligations and responsibilities, on the strength of the warranty card to sell car units designated by the maintenance department enjoys a "3 Guarantee "service, specific provisions are as follows:

1 "3 Guarantee" in the scope of the repair, replacement or return

- ① please check on the car when your car, and is entitled to request sales staff to provide effective bill and warranty card, as well as the maintenance unit's address and telephone number.
- ② after a car you should read the instruction for use, to master the correct method of use and daily maintenance and matters needing attention, If the electric car to don't yet know what use people, must be paid to the interpretation, lest cause accidental damage.
- ③ user operation when used properly according to product manuals within 7 days from the date of products sold in performance failure. Consumers can choose a replacement or repair.
- ④ in 3 guarantee of period of validity, Canon repair many times to repair that cannot be used properly, the strength of the repair units to provide repair records and certificate, identified through after-sales service of the company headquarters, can exchange models of products for consumers, changing the same products, in accordance with the provisions, charging depreciation cost (2.7%), the vehicle every day, for the battery will not be used by the exchange.

2 Appraisal standard warranty

No	Part	Replace the standard	Can't replace the standard	Replace time
1	Hand cube	breakage	Improper use or man-made factors;	1 year
2	Fork	breakage; sealing-off	Improper use or man-made factors;	2 years
3	Framework	Breakage; sealing-off	①Improper use or man-made factors; ②Welding nut off; ③The changing structure of the framework;	2 years
4	Wheel tyre	Entire breakage; dew wire	①Improper use or man-made factors; ②Over wear;	3 month
5	Motor	Bearing broken; Casing damage	①Improper use or man-made factors; ②Corroded broken or polluted; ③Missing parts or don't match;	2 years
6	Controller	failure	Improper use or man-made damage;	1 year

